

A STEP BEYOND
IN AFFORDABLE MOBILITY



THE ESARCO™
SS-300



ESARCO 8 x 8 ALL TERRAIN VEHICLE

SPECIFICATIONS:

Height.....	96"
Length (without pintle hook)	199"
Width.....	88"
Height-Top of Dash.....	62"
Curb Weight.....	7000#
Payload-Offroad.....	5000#
Track.....	74"
Bed Length.....	120"
Bed Width.....	88"
Bed Height.....	42"
Ground Clearance.....	11"
Wading Depth.....	34"
Max Gradability.....	45 Degrees
Ramp Brake Over Angle.....	90 Degrees
Approach Angle.....	45 Degrees
Departure Angle.....	60 Degrees
Turning Circle-Inside.....	120"
Average Ground Pressure-Empty.....	11 psi
Average Ground Pressure-Loaded.....	19 psi
Highway Speed.....	60 MPH

Power Components: STANDARD PACKAGE

ENGINE: Ford 4.9L Gas-120 HP

TRANSMISSION: Ford C6 (Automatic)-3 Speed

AXLES: Four DANA 60 Axles (2 steer, 2 rigid)

BRAKES: Ford F Series Disc Brakes-Power Assisted

TIRES: Offroad Type

POWER STEERING: Standard

SUSPENSION: Coil Spring with Off Road Shock Observers for Maximum Mobility

FUEL CAPACITY: 22 Gallons

TRANSFER CASES: 2 Speed with Front and Rear Axle Disconnect

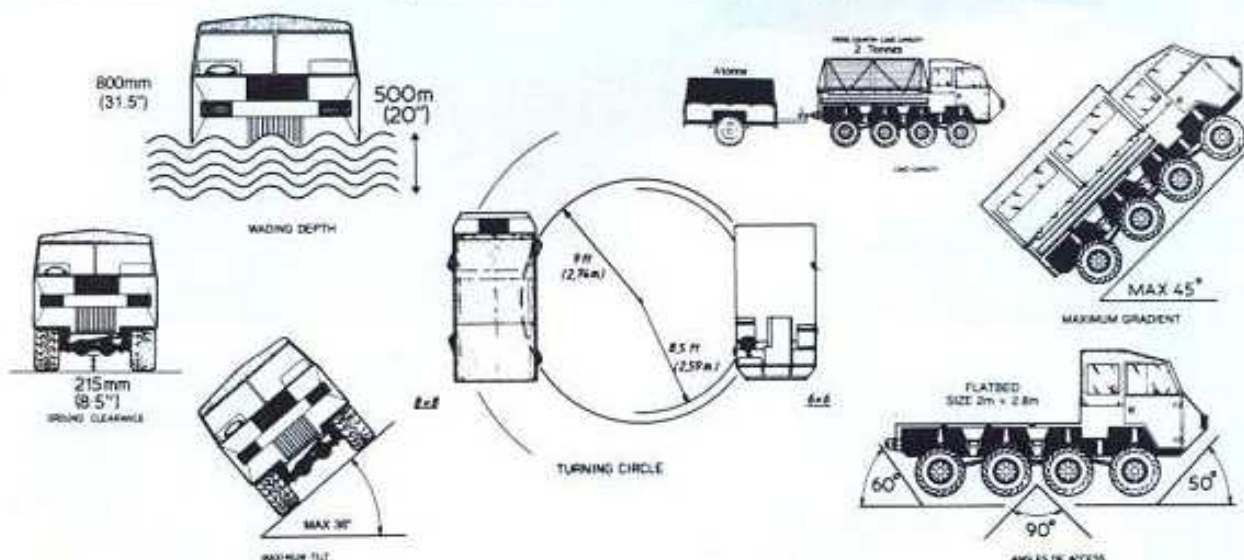

NOTE 1: A new Cab has been designed and will be fitted to the SS-300 in July 1988. The new Cab tilts open for ease of maintenance and features a human engineered interior for maximum comfort.

NOTE 2: Most of the components on the SS-300 are off-the-shelf automotive parts from FORD.

Optional Extras for Esarco Vehicles

Winch (mechanical/electrical), Towhook (NATO/Pintle/50mm ball), Wiring kit for towing, Weather protection, Run-flat tyre system, Seating for 8 men (6 x 6 only), Flotation tanks on hull (6 x 6 only), Tracks for rear axles (6 x 6 only), Seat for 10 men (8 x 8 only), Tracks for two centre axles if required (8 x 8 only).

Specialist fits to customer's requirements.



Low ground pressure keeps ESARCO at work in any shifting terrain—from the driest, sandiest desert to sinking, muddy fields.



With all 8-wheel drive, oversized coil springs and off-road shock absorbers, nothing stops the ESARCO. And with a simple shift to 4-wheel drive, the ESARCO is ready for cruising on the other side of a difficult crossing.



Flexible, durable... on the job.

OPTIONAL USES (MADE TO ORDER).

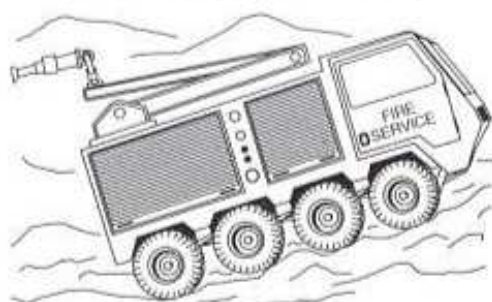

Maximum adaptability is the key to the ESARCO

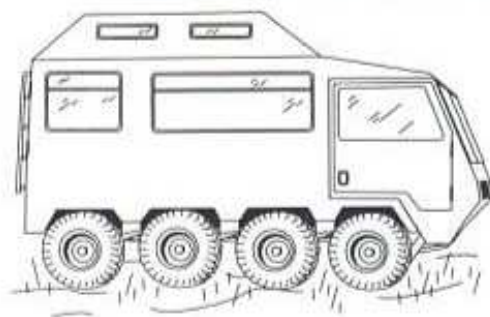



E

ngineered for maximum side-to-side stability on tough slopes, this multi-purpose truck not only does the job, but gets you there to do it.

W

hen the rain comes down and the water rises, the ESARCO stays on the job with a wading capability of nearly 3 feet ... without any advanced preparation.

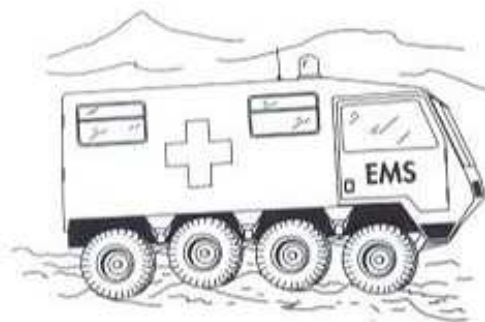



With Ford gasoline or diesel-powered engines, this off-road machine is an on-road performer ... at highway speeds. A quick shift from 8-wheel drive to 4-wheel drive ensures maximum performance and minimum tire wear. Plus driver's panoramic view and comfort is unmatched by vehicles in its class.

T

his truck doesn't get bogged down in muddy terrain. It slams through the earth's most demanding challenges to get the job done ... and done right.

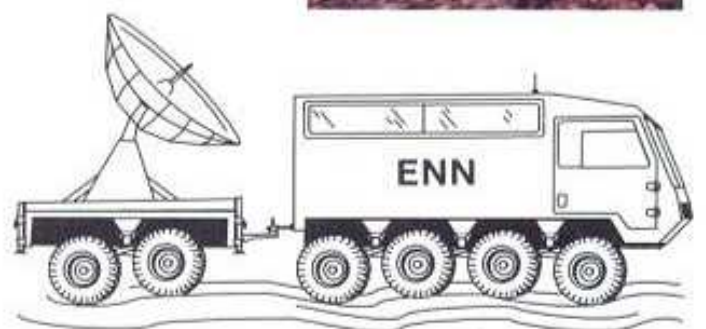



A

flatbed that knows the meaning of work, the ESARCO is a versatile machine engineered to adapt to your every need. Typical application options include a front mounted winch, a hydraulic telescope crane and a standard dropside cargo body.

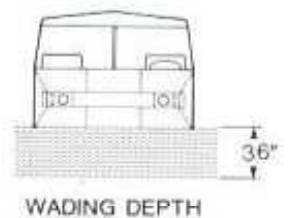
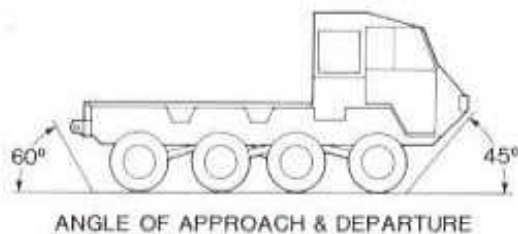
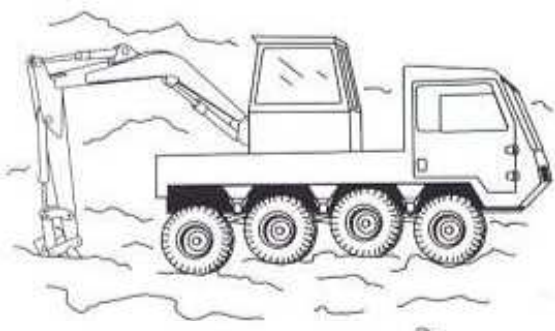
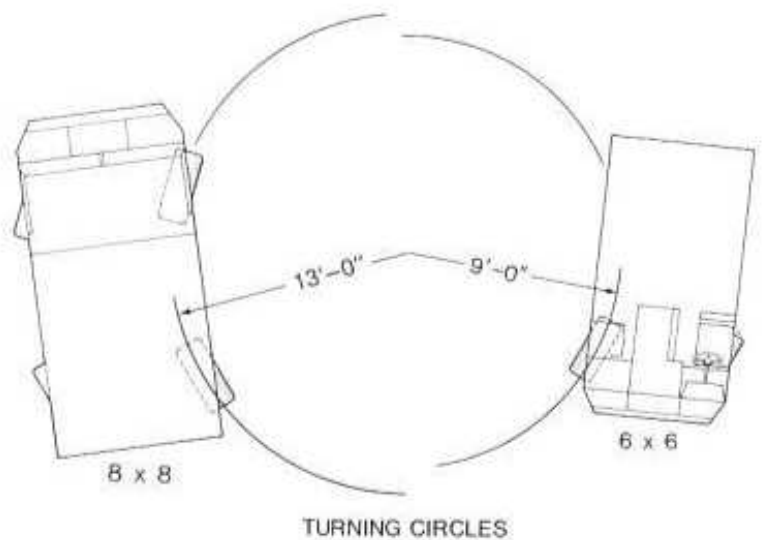
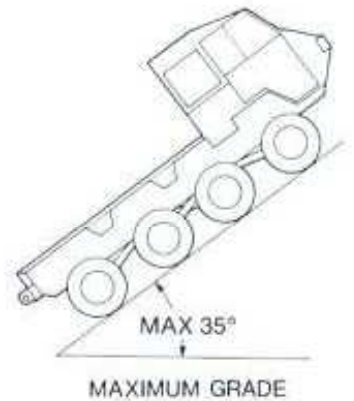
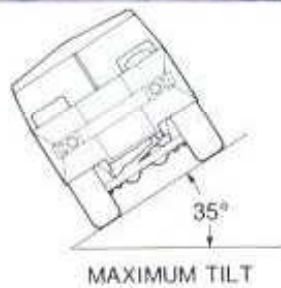

A BREAKTHROUGH IN ENGINEERING SIMPLICITY

The ESARCO combines patented technology with simple off the shelf componentry and conventional drive controls for a truck that drives easily, runs hard and repairs fast. By selecting Ford Power components for this flexible multi-use truck, designers ensured that it could run on terrain as rugged and as diverse as the Canadian mountains and the Saudi desert—and that parts and service would be available either place. In 8-wheel drive, grades of up to 35 degrees and 35 degree tilts provide maximum flexibility in all terrains.

The ESARCO pushes through water nearly three feet deep without stopping ... and drives on roads with the same ease as any road truck, at highway speeds.

Equipped with 8-wheel drive for the toughest off-road terrains, and 4-wheel drive for highway cruising, the ESARCO switches over with a simple shift.

This truck's a worker that outclasses the competition. Adaptable to every need, the ESARCO can tow and carry up to two and one-half tons ... for jobs too tough for other trucks.



A STEP BEYOND
IN AFFORDABLE MOBILITY
The ESARCO

The ESARCO all-wheel drive truck is offered to buyers
in the United States and Canada through
Stewart & Stevenson Services, Inc. and internationally
through ESARCO International, Inc.



ESARCO International, Inc.
Corporate Headquarters
Rensselaer Technology Park
120 Defreest Drive
Troy, New York 12180
518-283-3128



Stewart & Stevenson Services, Inc.
Corporate Headquarters
P.O. Box 1637
Houston, Texas 77251-1637
713-868-7700

As we are always seeking to improve our product, the information contained in this brochure is intended to provide only a general indication of performance, speed load capacity and other relevant equipment specifications. No part of this material should be interpreted to or shall form any part of any contract.